

ACCESORIOS AUTOMOTOR



ESPEJOS

RETROVISORES

GUARDAPOLVOS

TAPA EJES

TAPA PERNOS

TRANSP.

MASIVO





Ultra Panorámico de Alto Alcance



2-205

Especificaciones Técnicas:

- Espejo plástico cromado, ultra Panorámico de alto alcance.
- Soporte metálico acero inoxidable extensible y escualizable.
- Espejo especial para punto ciego o ángulo muerto. Evita accidentes y colisiones,

Usos y Aplicaciones:

- Tractocamiones, camiones, Volquetas, Carros de seguridad etc.
- use también el espejo solo (2-165) como auxiliar con abrazadera ó aleta.



CARENADO
(Derecho - Izquierdo)

2-199

Especificaciones Técnicas:

- Brazo internamente reforzado en Aluminio.
- Luna grande plana escualizable.
- Dos Lunas pequeñas panorámicas escualizables.
- Porta Lunas plástico.
- Base de aluminio para mejor fijación a la carrocería.
- Con direccional en Led.

Usos y Aplicaciones:

- Para buses intermunicipales, interdepartamentales, internacionales y de lujo.

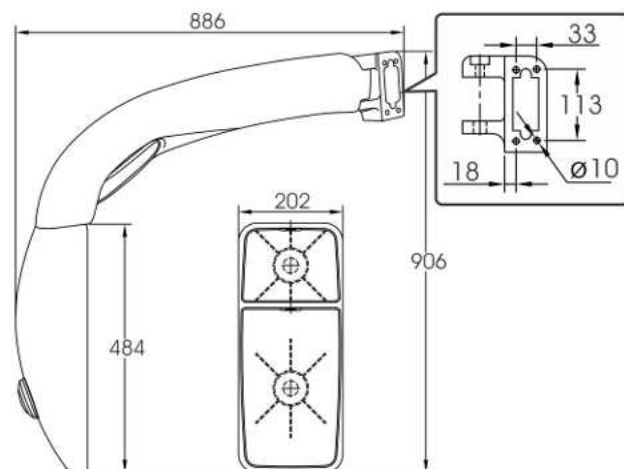



**Luz de Seguridad
ámbar multivoltaje.**

**Direccional y
Estacionarias**

- Direccional punto ciego (intermitente).
- Dos posiciones alta y baja.
- Multivoltaje 10v- 36v.

ELECTRICO
Tipo Marcopolo
MP 120
Generacion 6 (G6)
(Derecho - Izquierdo)



2-200P-L



JOYSTICK (MANDO)
PARA ESCUALIZACIÓN
DE LA LUNA



OPCIONAL
ACABADO
CROMADO
2-200P-4
2-200P-L-4
(con luz)

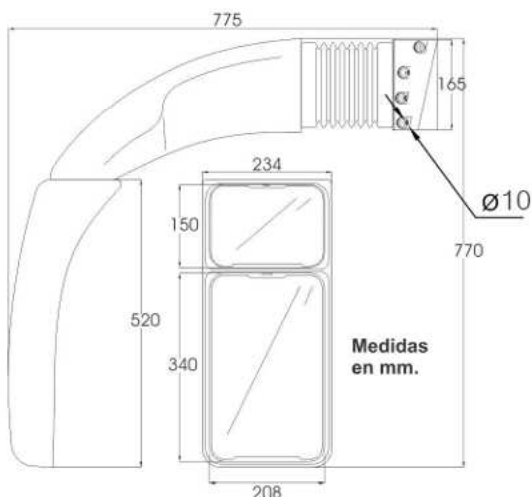

EURO STAR G6

2-200P-E

Especificaciones Técnicas:

- Copa y brazo plástico.
- Brazo internamente reforzado en Aluminio para mayor resistencia.
- Luna grande panorámica escualizable.
- Luna pequeña panorámica escualizable.
- Porta Lunas plástico.
- Base en aluminio.

Usos y Aplicaciones:

- Para buses intermunicipales, interdepartamentales, internacionales y de lujo.



Con Desempeñador

ELECTRICO
Tipo Marcopolo

Generacion 7 (G7)
(Derecho - Izquierdo)



2-206-E

DIMENSIONES DIRECCIONAL					
LONG.	ANCHO	ALTURA	DISTANCIA ENTRE CENTROS	PESO	# leds
88 mm	32 mm	39 mm	68 mm	25 g	4

Und	Volt. (v)	Lux	LUZ CRISTAL		LUZ AMBAR		
			Corriente Amperio (A)	Potencia Vatio (W)	Corriente Amperio (A)	Potencia Vatio (W)	
ALTA	24	14	0,01	0,24	7	0,01	0,24

Medición de la luminosidad bajo la norma NTC 303

Especificaciones Técnicas:

- Copa y brazo Fibra de vidrio acabado blanco
- Refuerzo interno estructura metálica
- Porta Lunas Abs negro
- Espejo principal Luna panorámica de 3 mm, ajustable eléctricamente mediante motor de 24 v, Joystick (mando) incluido para escualización de la luna, sistema calefactor, (50 -60)°C; 24V 35W
- Espejo Auxiliar Luna panorámica de 2 mm, ajustable manualmente
- Soporte 5 tornillos hexagonales rosca 10 mm x 90 mm
- Sujeción tornillos incluidos en el cuerpo
- Direccional incrustada en la copa sistema led 24V.

Ventajas:

- Resistente a la vibración
- Moldeable según la necesidad
- Mayor solidez en el cuerpo
- Alta resistencia al impacto
- Mayor precisión al escualizar
- Desempeñante en climas frios y lluviosos
- Resistencia a la intemperie
- Fácil instalación a la carrocería

Usos y Aplicaciones:

- Para tractomulas, buses intermunicipales, internacionales y de lujo



Con Direccional Led

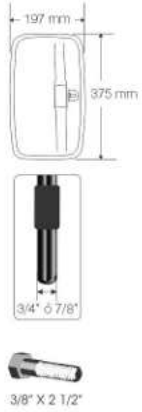

Multivoltaje / 10 Led

2-134-SL Espejo plástico. Con luz direccional



Multivoltaje / 10 Led

2-167L Espejo plástico. Con luz direccional



Multivoltaje / 10 Led

2-168L Espejo plástico / Luna auxiliar panorámica y escualizable. Con luz direccional.



Multivoltaje / 10 Led

2-169L Espejo plástico. Con luz direccional.

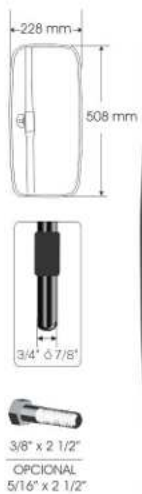

Multivoltaje / 10 Led

2-174L Espejo plástico. Con luz direccional.

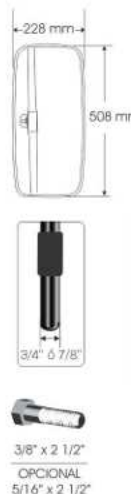

Multivoltaje / 10 Led

2-175L Espejo plástico / Luna auxiliar panorámica y escualizable. Con luz direccional.

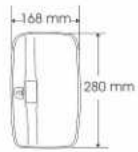

2-134-AP-S Espejo plástico.

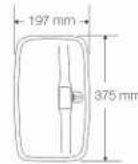

2-134-S Espejo plástico.

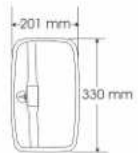

2-162 Espejo plástico.



2-163 Espejo plástico / Luna auxiliar panorámica y escualizable.



2-147 Espejo plástico / Luna auxiliar panorámica y escualizable.



2-167 Espejo plástico.



2-168 Espejo plástico / Luna auxiliar panorámica y esculpizable.



2-169 Espejo plástico.



2-174 Espejo plástico.



2-175 Espejo plástico / Luna auxiliar panorámica y esculpizable.



2-176 Espejo plástico.



2-177 Espejo plástico / Luna auxiliar panorámica y esculpizable.



1/4" x 1 1/2"



2-151 Espejo plástico. Escualizable Tipo NPR



1/4" x 1 1/2"



2-153 Espejo plástico. Escualizable Tipo NPR



LISO

2-117L-IX

Espejo en Acero Inoxidable

2-117L4

Espejo metálico cromado,



NUEVO



2-117CL-IX

Espejo en Acero Inoxidable

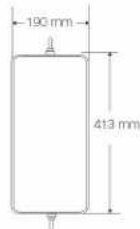

2-178

Espejo plástico,
Cromado, aro en acero
inoxidable. Kenworth

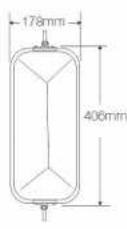

2-79-AP

CHEVROLET, Espejo plástico crema o cromado.

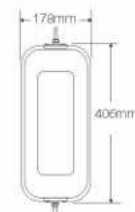

2-3-AP-4

UNIVERSAL,
Espejo plástico, cromado liso

2-3-AP-5

Espejo plástico, Crema liso





NUEVO



2-140/1-123-13

Espejo plástico "Panorámico"
Soporte metálicopintado.
Izquierdo - Derecho,
Buses padrones,
alimentadores articulados y
biarticulados, transporte
masivo



2-140/1-121-13

Espejo plástico "Panorámico"
Soporte metálico pintado.
Izquierdo - Derecho,
Buses padrones,
alimentadores articulados y
biarticulados, transmlenio
transporte masivo

NUEVO

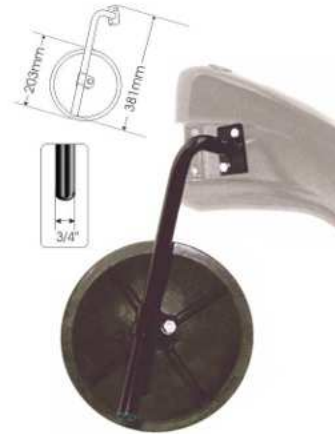

2-164/1-122-13

Espejo Panorámico 8"
con brazo auxiliar,
Buses articulados transmlenio.



2-164/1-124-13

Espejo Panorámico 8"
con brazo auxiliar,
Buses articulados transmlenio.



1-115-13

Soporte Tipo buscar, Lado izquierdo,
Buses articulados transmlenio.



1-114-13

Soporte Tipo buscar Lado Derecho
Buses articulados transmlenio.

PADRÓN Y ARTICULADO

VIALE,
GRAN VIALE



1-141D

Soporte Aluminio fundido Tipo Marcopolo, Viale y Gran vial,
Lado derecho, Buses articulados transmlenio.



1-119-13 I/D

Soporte Tipo Marcopolo,
Izquierdo - derecho,
Buses articulados transmlenio.



1-120D

Soporte Tipo Marcopolo,
Lado derecho,
Buses articulados transmlenio.



1-150

Tipo biarticulado
Soporte Recubierto en Poliuretano, alma metálica.
Izquierdo
Buses urbanos, articulados, Transporte masivo

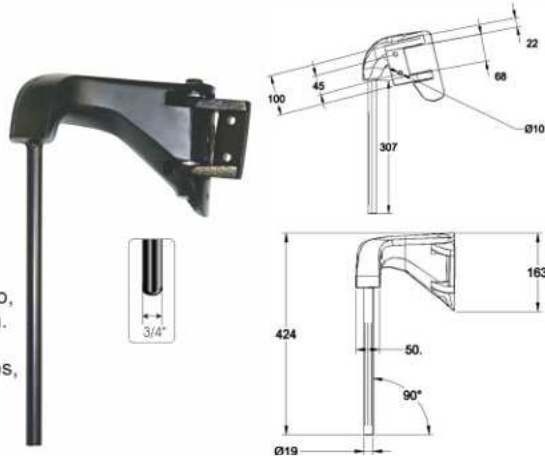

1-151

Soporte Tipo Optimus
Herraje en Aluminio fundido
Izquierdo- Derecho
Buses urbanos, articulados
Transporte masivo



1-144I/D

Soporte Tipo Marcopolo
New Senior.
Herraje en aluminio fundido
Izquierdo - Derecho.
Buses urbanos, articulados, transporte masivo



1-147I/D

Soporte Tipo Blue Bird
Herraje en aluminio fundido
Izquierdo - Derecho.
Buses urbanos, articulados, transporte masivo



1-140I/D

Herraje en aluminio fundido,
Izquierdo - Derecho.



1-102I/D

Soporte con varilla corrugada de Ø 1/2", recubierta en poliuretano, Soporte Ø 3/4" pintado negro, **Izquierdo - Derecho.**



1-104I/D

Soporte con varilla corrugada de Ø 1/2", recubierta en poliuretano, Soporte Ø 3/4" pintado negro, **Izquierdo - Derecho.**



1-106I/D-13

Soporte con varilla corrugada de Ø 1/2", recubierta en poliuretano, Soporte Ø 3/4" pintado negro, **Izquierdo - Derecho.**



PADRÓN Y ARTICULADO VIALE, GRAN VIALE

1-145I

Soporte Tipo Marcopolo, Herraje en aluminio fundido Lado izquierdo, Buses articulados transmilenio.

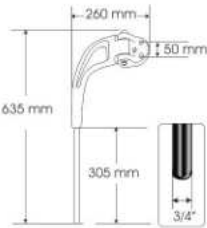

PADRÓN Y ARTICULADO VIALE, GRAN VIALE

1-146D

Soporte Tipo Marcopolo, Herraje en aluminio fundido Lado derecho, Buses articulados transmilenio.

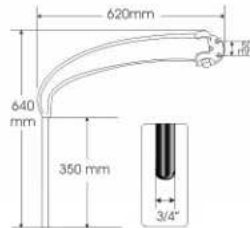

1-128I/D

Soporte Tipo Busscar, Izquierdo - derecho Buses articulados transmilenio.

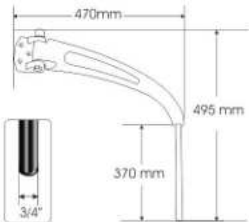

1-130 I/D

Soporte y base metálico Herraje en aluminio fundido Largo. Tipo Mercedes, Izquierdo - Derecho

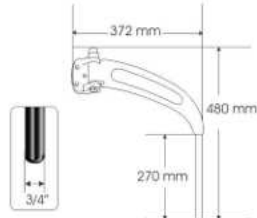

1-131 I/D

Soporte y base metálico Herraje en aluminio fundido Mediano. Tipo Mercedes, Izquierdo - Derecho

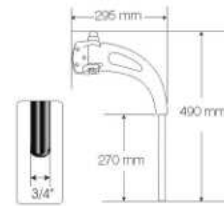

1-132 I/D

Soporte y base metálico Herraje en aluminio fundido Corto. Tipo Mercedes, Izquierdo - Derecho



1-135 I/D

Soporte metálico recubierto con poliuretano. Base pintado negro, Izquierdo - Derecho



SOPORTE TIPO CAIO BUSES TRANSPORTE MASIVO

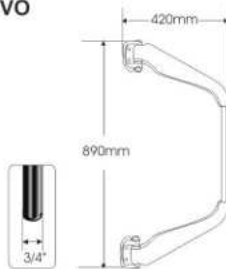

1-136

Soporte negro recubierto con fibra de vidrio



1-137

Soporte negro, recubierto con fibra de vidrio. Izquierdo - derecho



SENIOR



2-167/1-119/D13

Soporte pintado negro reforzado con varilla Ø1/2", recubierta con poliuretano. **izquierdo - derecho**, Soporte: Ø3/4"

SENIOR

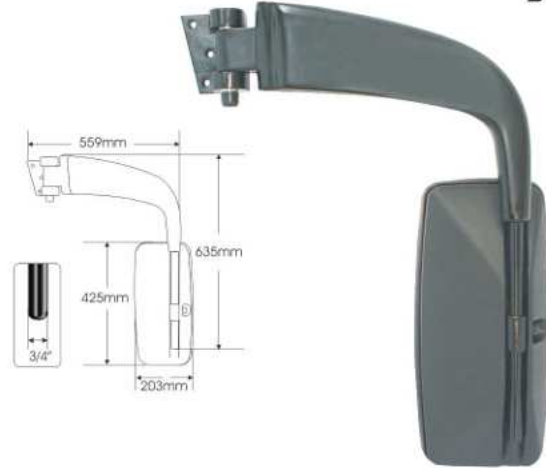

2-169/1-119/D13

Espejo **panorámico** soporte pintado negro, reforzado con varilla Ø1/2", recubierta con poliuretano, **izquierdo - derecho**. Soporte: Ø3/4"

SENIOR



2-174/1-120D13

Espejo **plano** soporte pintado negro, reforzado con varilla Ø1/2", recubierta con poliuretano, **derecho**. Soporte: Ø 3/4"



2-147/1-102I/D

Doble espejo: Espejo **plano** y Espejo **panorámico** móvil, soporte pintado negro reforzado con varilla Ø1/2", recubierta con poliuretano. **izquierdo - derecho**, Soporte: Ø3/4"



2-163/1-102I/D

Panorámico doble luna.

2-162/1-102I/D

Espejo panorámico soporte pintado negro, reforzado con varilla Ø1/2", recubierta con poliuretano, **izquierdo - derecho**. Soporte: Ø 3/4"

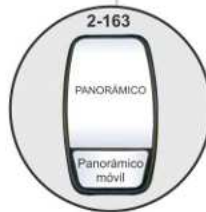

2-163/1-104I/D

Panorámico doble luna.

2-162/1-104I/D

Espejo Panorámico soporte pintado negro, reforzado con varilla Ø1/2", recubierta con poliuretano, **izquierdo - derecho**. Soporte: Ø 3/4"



2-169/1-104I/D

Soporte pintado negro reforzado con Varilla $\varnothing 1/2"$, recubierta con poliuretano. **Izquierdo - derecho**
Soporte: $\varnothing 3/4"$



2-134/1-104I/D

Soporte pintado negro reforzado con Varilla $\varnothing 1/2"$, recubierta con poliuretano. **Izquierdo - derecho**
Soporte: $\varnothing 3/4"$



2-163/1-106I/D

Panorámico doble luna.

2-162/1-106I/D

Espejo panorámico soporte reforzado, pintado negro, recubrimiento en poliuretano, **Izquierdo - derecho**. Soporte: $\varnothing 3/4"$



2-163/1-118I/D

Panorámico doble luna. Soporte pintado negro, recubierta con poliuretano. **Izquierdo - Derecho**



2-134AP/1-91I/D

Soporte pintado negro, **izquierdo-derecho**. Tipo Jeep Willys.



2-134-AP-4

Espejo cromado

2-134-APD/I-13 Soporte pintado negro, Ambos lados.

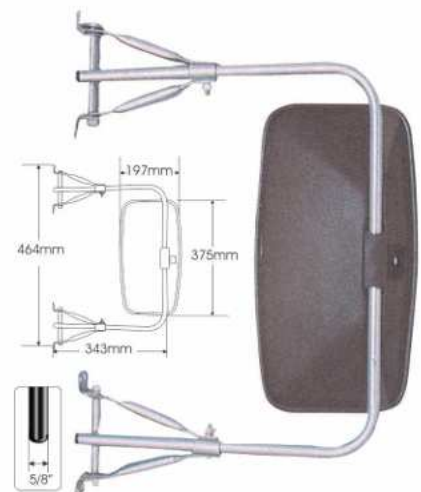

2-134D-13 Soporte cromado.



EXTENSIBLE



2-103-A/1-25

Espejo plástico cromado, soporte zincado extensible

DODGE 600

2-3-A/1-26IX
soporte en acero inoxidable

2-3-A/1-26
Aro ancho, espejo plástico cromado soporte cromado Dodge 600.

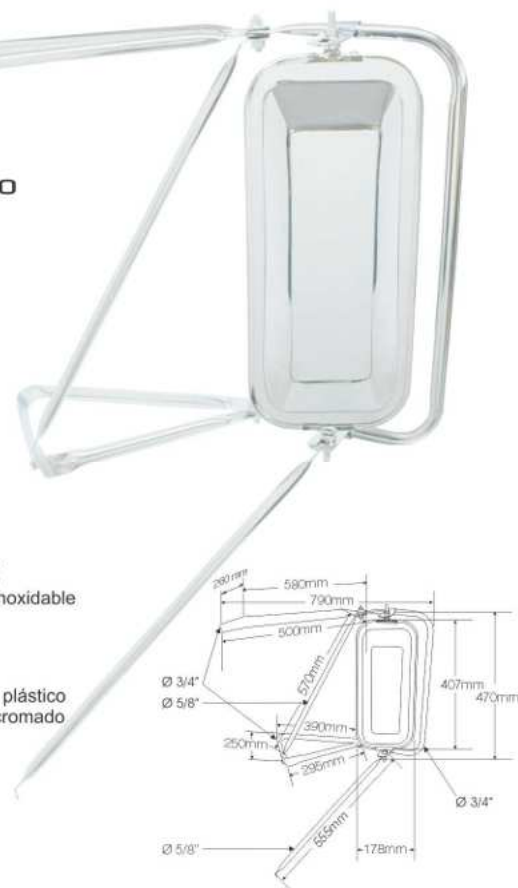

CHEVROLET C70

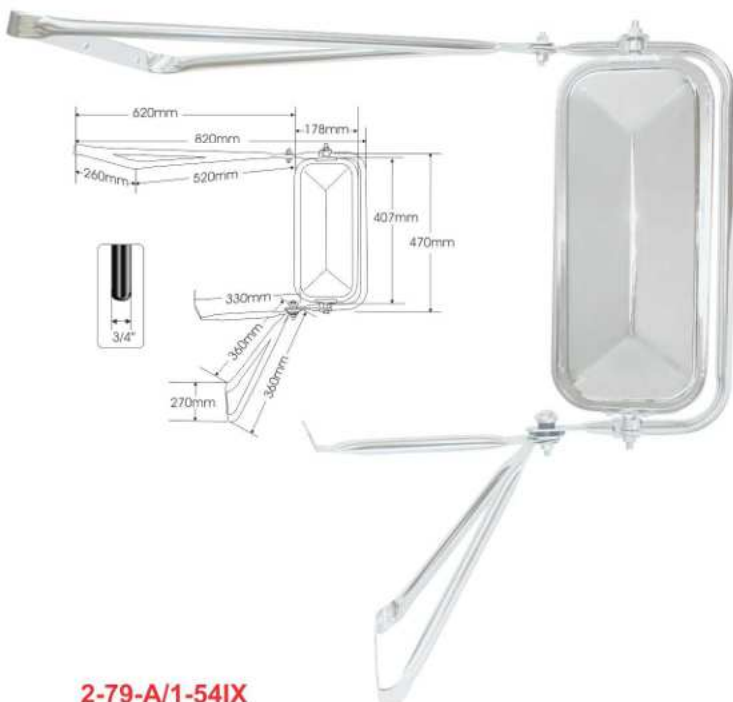

2-79-A/1-54IX

Soporte en acero inoxidable

2-79-A/1-54/D

Espejo plástico cromado, Soporte pintado o cromado, Chevrolet C-70

8"



2-164/1-116IX

Soporte Acero Inoxidable

2-164/1-116

Espejo plástico, cromado, Panorámico
Soporte cromado, en forma de Tripode.
Extensible y ajustable. Buses, camiones y Tractocamiones.
Soporte: Ø 3/4"



2-165A
Espejo plástico con abrazadera

2-165
Espejo plástico cromado, con aleta y bola tornillo.
"Panorámico" con aleta

- **2-165A-13** Negro
- **2-165-13** Negro



2-207
Espejo Auxiliar Panorámico soporte curvo con plataforma.



2-209
Espejo Auxiliar Panorámico bastón rosca 5/16"



2-212
Espejo Auxiliar Panorámico soporte curvo con plataforma. Buses biarticulados.



3-45 Plano

3-45 PN Panorámico soporte curvo en nylon reforzado con fibra de vidrio. Retrovisor interior.



2-164A
Espejo plástico con abrazadera

2-164
Espejo plástico cromado, con aleta y bola tornillo.
"Panorámico" con aleta



2-164/1-8-4
Espejo conjunto plástico, Panorámico cromado, soporte zincado articulado

- **2-164A-13** Negro
- **2-164-13**



2-140PN-14 Rojo
2-140PN-13 Negro
2-140PN-16 Verde
2-140PN-4 Espejo plástico cromado, bola tornillo, Luna Panorámica
Soporte: abrazadera cromada para tubo Ø (3/4")



2-115PAN-4
Espejo panorámico plástico cromado,

2-115PAN-13
Espejo Panorámico plástico negro



2-141/1-8-5
Espejo conjunto plástico plano crema

2-141/1-8PN-8
Espejo conjunto plástico Panorámico gris

2-141/1-8PN-13
Espejo conjunto plástico Panorámico negro, soporte zincado articulado.



2-23-P-4 Espejo plástico plano cromado

2-23-AP-13 Espejo plástico panorámico negro

2-23-AP-4 Espejo plástico cromado, bola tornillo "panorámico" con abrazadera cromada.



2-202-4
Espejo plástico cromado,
soporte zamack cromado



2-208D/I
Espejo plástico negro
Luna Panorámica,
Bastón soporte varilla de Ø 1/2"
Alta resistencia al impacto
Buses, Busetas, Transporte masivo

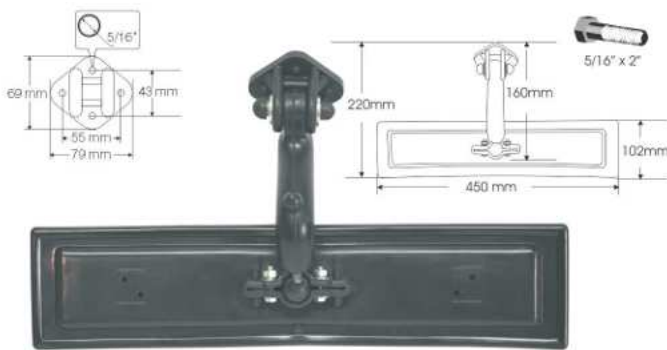

3-36 Espejo plástico, Luna Panorámica, soporte plástico Corto.

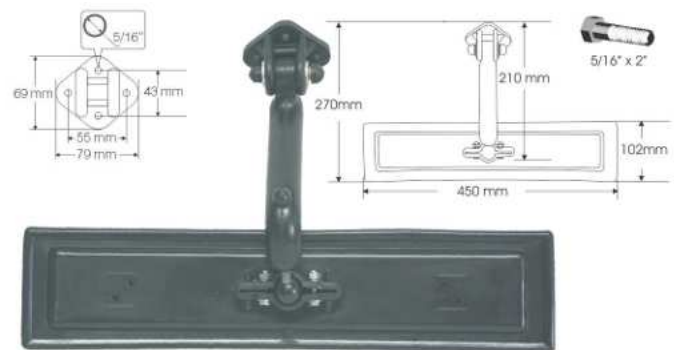

3-37 Espejo plástico, Luna Panorámica, soporte plástico Largo.



3-38
Espejo Plástico, luna plana,
soporte metálico pintado.

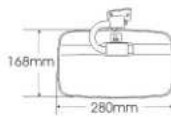

3-40
Espejo plástico, interior,
luna plana, soporte
abrazadera tornillo.
Buses articulados.

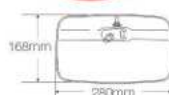

3-39
Espejo plástico,
interior autobus, luna
plana.

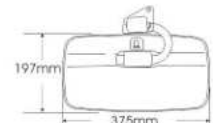

3-43
Espejo plástico, luna Panorámica.
Soporte plástico negro.

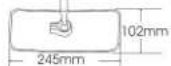

3-28-A
Espejo plástico negro, para pegar al parabrisas
soporte plástico

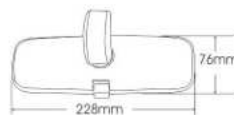

3-1
Espejo plástico negro, soporte metálico pintado.

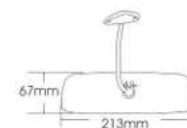



2-60/1-32

Espejo plástico cromado, Izquierdo - derecho, Soporte cromado.



2-60/1-89

Espejo plástico cromado, Izquierdo - derecho, Soporte cromado.



2-78P-4

Espejo y soporte plástico cromado, Camioneta C-10



2-100

Espejo plástico cromado, soporte en zamack cromado.

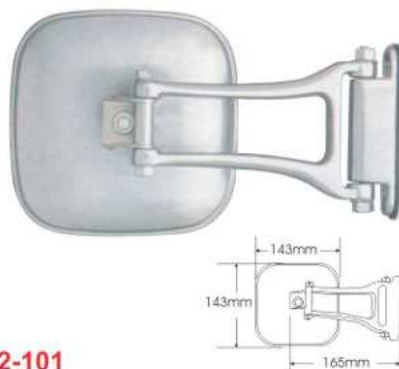

2-101

Espejo plástico cromado, soporte en zamack cromado.



2-130D/I-13

Espejo Plástico negro

2-130D/I-4

Espejo Plástico cromado, izquierdo - derecho, soporte curvo pintado. Mitsubishi.



2-58/1-42D/I

Espejo plástico gris, izquierdo - derecho, soporte gris campero Toyota.



2-58

Espejo plástico gris o negro, campero Toyota.



2-57

Espejo plástico negro, luna no intercambiable, ambos lados, soporte metálico pintado, Trooper



2-115/1-70

Espejo plástico negro o cromado, izquierdo - derecho, luna plana, soporte metálico pintado, negro o cromado, campero Toyota.



2-22-P4

Espejo plástico cromado. bola tornillo



2-81-P13 Espejo negro.



2-81-P8 Espejo Plástico gris, campero Nissan.



2-118-4D-I

Espejo plástico cromado, soporte plástico negro, Chevrolet Luv 1600 y 2000



2-118-13D/I

Espejo plástico negro, soporte plástico negro, Chevrolet Luv 1600 y 2000



2-56D/I

Espejo plástico negro, soporte plástico negro.



2-135-A-4D/I

Espejo plástico cromado, soporte **largo**, plástico negro. campero Toyota Macho y camioneta 4 x 4.

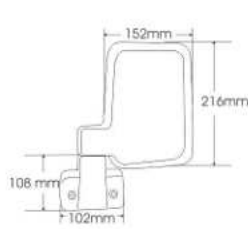

2-135-A-13D/I
Espejo plástico negro

LUNA
ESCUALIZABLE



2-135-B-4D/I

Espejo plástico cromado, soporte **corto**, plástico negro. campero Toyota Macho y camioneta 4 x 4.

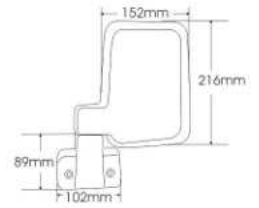

2-135-B-13D/I
Espejo plástico negro



2-136-4D/I

Espejo plástico cromado, soporte plástico negro, Chevrolet Luv 2300

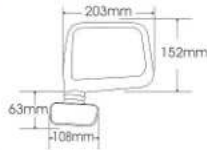

2-136-13D/I

Espejo plástico negro, soporte plástico negro, Chevrolet Luv 2300

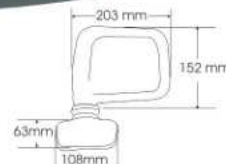

2-155D/I

Espejo plástico " panorámico", Soporte plástico negro.

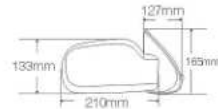

2-158D/I

Espejo plástico, luna plana. Soporte plástico negro.



2-159D/I

Espejo plástico " panorámico" Soporte plástico negro. Chevrolet Corsa.

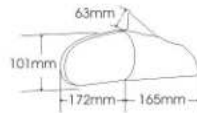

2-166D/I

Espejo plástico, luna plana. Soporte plástico negro. Chevrolet Sprint.

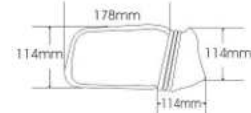

2-51-4

Espejo plástico **cromado**, ambos lados, soporte plástico negro. Renault 4-6-12 y 12 Break.

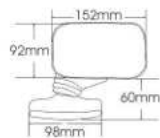

2-51

Espejo plástico **negro**, ambos lados, soporte plástico negro. Renault 4-6-12 y 12 Break.

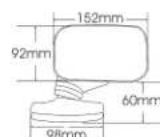

2-38D/I

Espejo plástico negro, izquierdo-derecho, Soporte plástico negro. Renault 4plus y 18.

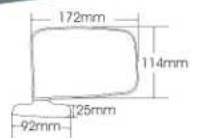



Tipo Transporte Público

18-050
STAR

NUEVO



18-050T
STAR



Espacio superficie lisa para pegar publicidad

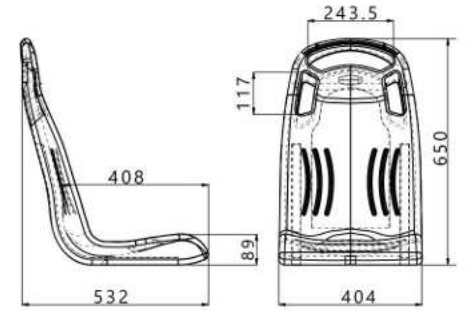

18-020
EURO



18-040
COMFORT PLUS



Espacio superficie lisa para pegar publicidad

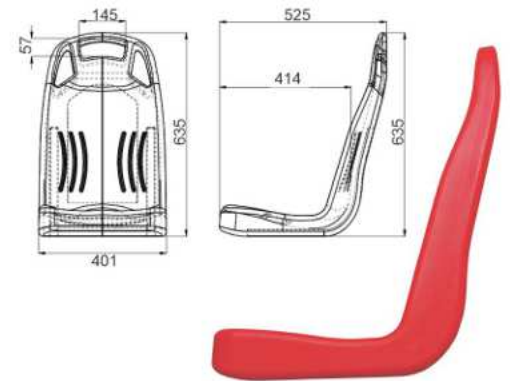

18-020T
EURO



18-010
METRO

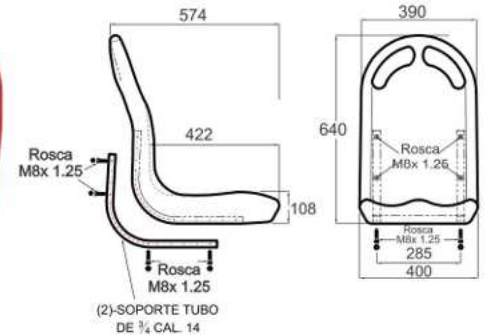

18-020AT
EURO



18-000
CONTINENTAL

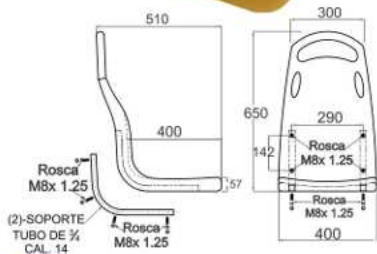
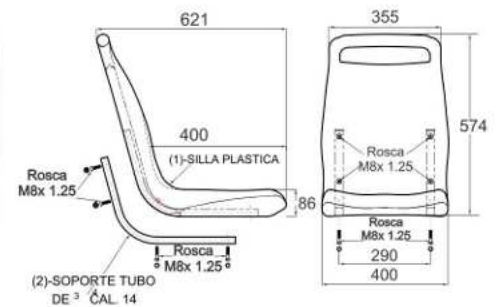



11-107

**ABRAZADERA PLASTICA
PARA TUBO Ø 1 1/4"**



11-108

**ABRAZADERA PLASTICA
PARA TUBO Ø 1 1/4"**



11-115A

**ABRAZADERA PLASTICA
PARA TUBO Ø 1 1/4"**
Tipo T



11-109

**SOPORTE PLASTICO
DE PASAMANOS
PARA TUBO Ø 1 1/4"**



11-110

**SOPORTE PLASTICO
DE PASAMANOS
PARA TUBO Ø 1 1/4"**



11-121

**SOPORTE PLASTICO
ASIENTO / PASAMANOS
PARA TUBO Ø 1 1/4"**



11-111

**SOPORTE PLASTICO
DE PASAMANOS
PARA TUBO Ø 1 1/4"**

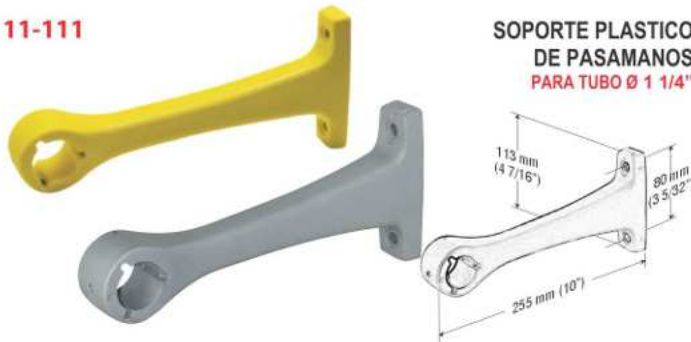

11-113

**SOPORTE PLASTICO
DE PASAMANOS
PARA TUBO Ø 1 1/4"**

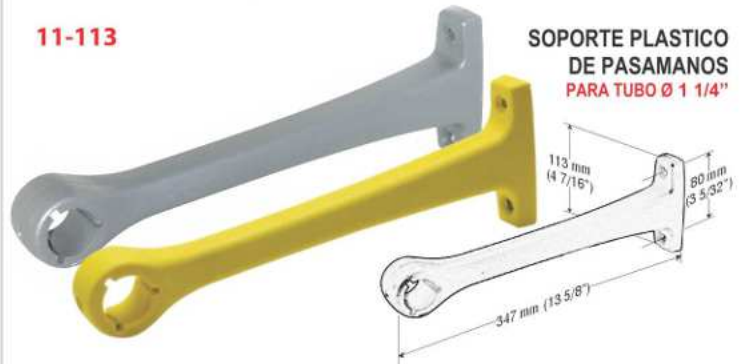

11-129

**SOPORTE PLASTICO DE PASAMANOS
PARA TUBO Ø 1 1/4"**
2 abrazaderas que forman la cruz



11-130

**SOPORTE PLASTICO DE PASAMANOS
PEGA MAO
PARA TUBO
Ø 1 1/4"**



11-112

**REJILLA
TIPO BUSSCAR**
Panel Frontal Aire Acondicionado
Autobuses Articulados

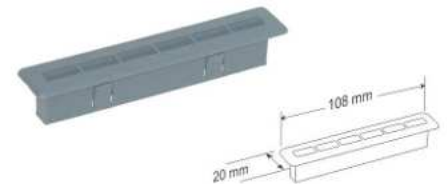

R09-021

**LENTE DE SEGURIDAD
TIPO BUSSCAR**
Autobuses Articulados

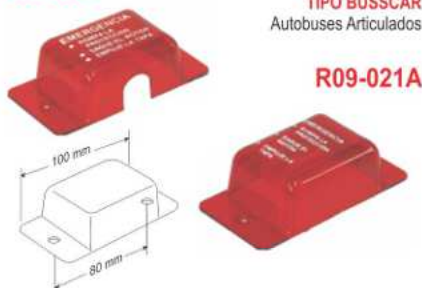

MANIJAS ASIDERO DE PUERTA
Manijas metálicas en
aluminio de 3/8".

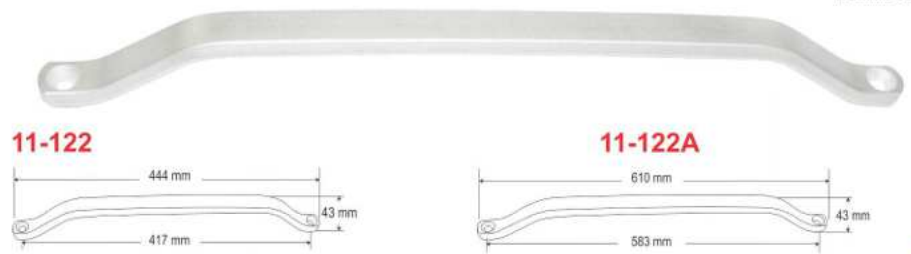



Transporte Masivo

11-126



REF.	CALIBRE TUBO	COLOR TUBO			DIMENSIONES TUBO (METROS)
		●	●	○	
011-126	14 / 16 / 18	1	8	2	2 / 4 / 6
011-127A	14 / 16 / 18	1	8	2	
011-127B	14 / 16 / 18	1	8	2	
011-127C	14 / 16 / 18	1	8	2	

Ejemplo: 011-126-14-1-6 = Tubo calibre 14 (14) color amarillo (1) 6 mts. (6)

TUBO REDONDO ENCAPSULADO DE 1. 1/8" X 6 mt, 4 mt, 2 mt Transporte Masivo C.R. CAL. 14 / 16 / 18

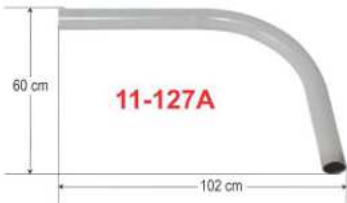

11-127A

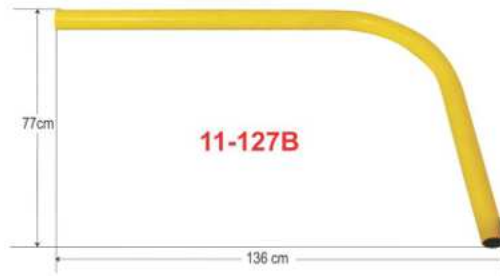

11-127B

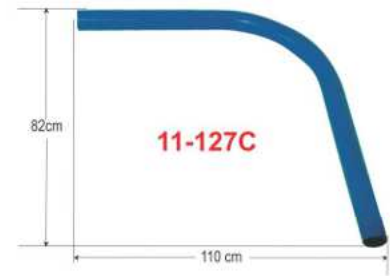

11-127C

14-041



14-093



14-118



14-094



14-095



14-059



14-060



14-063



14-090



ESCOBILLAS

TRANSPORTE MASIVO Y ELEVADORES DE DISCAPACITADOS puertas de ascenso y descenso buses de transporte de pasajeros.

14-041



14-093



14-118



14-094



14-095



14-059



14-060



14-063



14-090





17-020



TAPA EJE TRASERO
PLÁSTICA CROMADA



17-021



TAPA EJE DELANTERO
PLÁSTICA CROMADA



17-021P

TAPA EJE DELANTERO
+ 10 TAPA PERNOS
PLÁSTICOS CROMADOS

17-020P



TAPA EJE TRASERO
+ 10 TAPA PERNOS
PLÁSTICOS CROMADOS



17-019

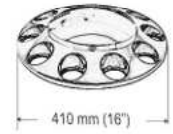

TAPA EJE DELANTERO **TIPO EUROPEA** PLÁSTICA CROMADA

17-022L

LISO

17-022

LISO CON REFLECTIVO



17-023

MEDIA ESFERA

17-024

CONICO

17-025

TIPOO BALA

17-026

LISO

17-027

LISO PRISMA

TIPO EUROPEO



** Tapa pernos disponible con hilo y a presión*



*** Color negro opcional en todas las referencias**





11-097 GUARDAPOLVO EN CAUCHO GRANDE

Guardapolvo en caucho, compuesto por fibra de nylon pulverizada para aguantar el desgarre. Flexible, resistente a la rotura, con refuerzo en lámina en la parte superior. El Logotipo es vulcanizado, no pintado evitando que se decolore. Para Tractomulas:

REF.	DESCRIPCION	DIMENSIONES
011-097-CH	Chevrolet	745 mm (29 5/16") x 600 mm (23 5/8")
011-097-CH-M	Chevrolet Mediano	575 mm (22 5/8") x 595 mm (23 7/16")
011-097-FD	Ford	745 mm (29 5/16") x 600 mm (23 5/8")
011-097-FD-M	Ford Mediano	575 mm (22 5/8") x 595 mm (23 7/16")
011-097-HINO	Hino	745 mm (29 5/16") x 600 mm (23 5/8")
011-097-H-M	Hino Mediano	575 mm (22 5/8") x 595 mm (23 7/16")
011-097-HI	International	745 mm (29 5/16") x 600 mm (23 5/8")
011-097-KW	Kenworth	745 mm (29 5/16") x 600 mm (23 5/8")
011-097-L	Liso	745 mm (29 5/16") x 600 mm (23 5/8")
011-097-MK	Mack	745 mm (29 5/16") x 600 mm (23 5/8")
011-097-MRC	Mercedes	745 mm (29 5/16") x 600 mm (23 5/8")
011-097-AT	Atta	745 mm (29 5/16") x 600 mm (23 5/8")

11-101



GUARDAPOLVO EN CAUCHO MEDIANO / GRANDE

Guardapolvo en caucho, compuesto por fibra de nylon pulverizada para aguantar el desgarre. Flexible, resistente a la rotura. El Logotipo es vulcanizado, no pintado evitando que se decolore. Para Tractomulas:

REF.	DESCRIPCION	DIMENSIONES
011-101-DI-M	Dite Mediano Negro	630 mm (24 6/8") x 270 mm (10 5/8")
011-101-DI	Dite Negro	630 mm (24 6/8") x 450 mm (17 3/4")

11-103



GUARDAPOLVO EN CAUCHO MEDIANO

Guardapolvo en caucho, compuesto por fibra de nylon pulverizada para aguantar el desgarre. Flexible, resistente a la rotura. El Logotipo es vulcanizado, no pintado evitando que se decolore. Para Tractomulas:

REF.	DESCRIPCION	DIMENSIONES
011-103	Liso	575 mm (22 5/8") x 595 mm (23 7/16")
011-103-IC	Inca	575 mm (22 5/8") x 595 mm (23 7/16")

11-104



GUARDAPOLVO EN CAUCHO PEQUEÑO

Guardapolvo en caucho, compuesto por fibra de nylon pulverizada para aguantar el desgarre. Flexible, resistente a la rotura. El Logotipo es vulcanizado, no pintado evitando que se decolore. Para Tractomulas:

REF.	DESCRIPCION	DIMENSIONES
011-104-IC	Inca	308 mm (12 2/16") x 647 mm (25 1/2")

Area de Inyección y transformación de Plásticos

Más de 40 Máquinas, entre: inyectoras, Máquinas de soplado, proceso de extrusión de plástico, y más de 3.200 moldes que permiten procesar un promedio de 100 toneladas mensuales de diferentes tipos de plásticos.



Inyectora. Para plásticos con horno secador, capacidad 4.000 gramos.



Centro de Mecanizado Optimiza la producción de moldes por medio de un magazín de 30 herramientas controladas por un PC fusionado en un CNC. Con refrigeración interna en el husillo y unas velocidades de avance de 33m /minuto.



Sopladora. Optimiza el proceso de soplado, especial para asientos para transporte masivo.



Torno. Mejoramiento de la productividad y calidad de las piezas



Exportamos a México • Perú • Panamá • Honduras • Chile
• Ecuador • Salvador • Guatemala • Costa Rica
• Nicaragua • República Dominicana

**RUEDAS Y RODACHINES,
ACCESORIOS PARA AUTOMOTOR Y MOTOS,
ARTÍCULOS PARA EL HOGAR,
ASIENTOS PARA ESTADIOS TRIBUNAS Y AUDITORIOS.**



Call Center 315 581 3863

Fábrica Cali PBX: (57) (602) 884-1020

Bogotá (57) 601 310-6529

Medellín / Barranquilla / Bucaramanga

e-mail: multiventas@multipartes.com

www.multipartes.com

